



US 20160133877A1

(19) **United States**

(12) **Patent Application Publication**  
**MATSUMOTO et al.**

(10) **Pub. No.: US 2016/0133877 A1**  
(43) **Pub. Date: May 12, 2016**

(54) **DISPLAY DEVICE**

(71) Applicant: **Japan Display Inc.**, Tokyo (JP)

(72) Inventors: **Yuko MATSUMOTO**, Tokyo (JP);  
**Toshihiro SATO**, Tokyo (JP); **Hiroshi OOOKA**, Tokyo (JP)

(21) Appl. No.: **15/001,554**

(22) Filed: **Jan. 20, 2016**

**Related U.S. Application Data**

(63) Continuation of application No. 14/146,807, filed on Jan. 3, 2014, now Pat. No. 9,269,922.

**Foreign Application Priority Data**

Jan. 4, 2013 (JP) ..... 2013-000247

**Publication Classification**

(51) **Int. Cl.**  
**H01L 51/52** (2006.01)  
**H01L 27/32** (2006.01)

(52) **U.S. Cl.**

CPC ..... **H01L 51/5268** (2013.01); **H01L 27/3246** (2013.01); **H01L 51/5253** (2013.01); **H01L 51/5271** (2013.01); **H01L 51/524** (2013.01); **H01L 51/5203** (2013.01); **H01L 2251/558** (2013.01)

(57) **ABSTRACT**

An organic EL display device includes a first substrate, a plurality of organic EL devices arranged on the first substrate, a second substrate arranged above the first substrate, and a filling layer arranged between the first substrate and the second substrate, and displays an image on the second-substrate side. The organic EL display device is characterized in that: the organic EL devices each have a light-emission layer, a reflection electrode formed below the light-emission layer and reflecting light from the light-emission layer upwards, and an upper electrode formed above the light-emission layer and having a light transmission property and reflectivity; a structure for resonating the light emitted by the light-emission layer is formed between the reflection electrode and the upper electrode; and the filling layer includes fine particles for diffusing light exiting from the upper electrode added therein.

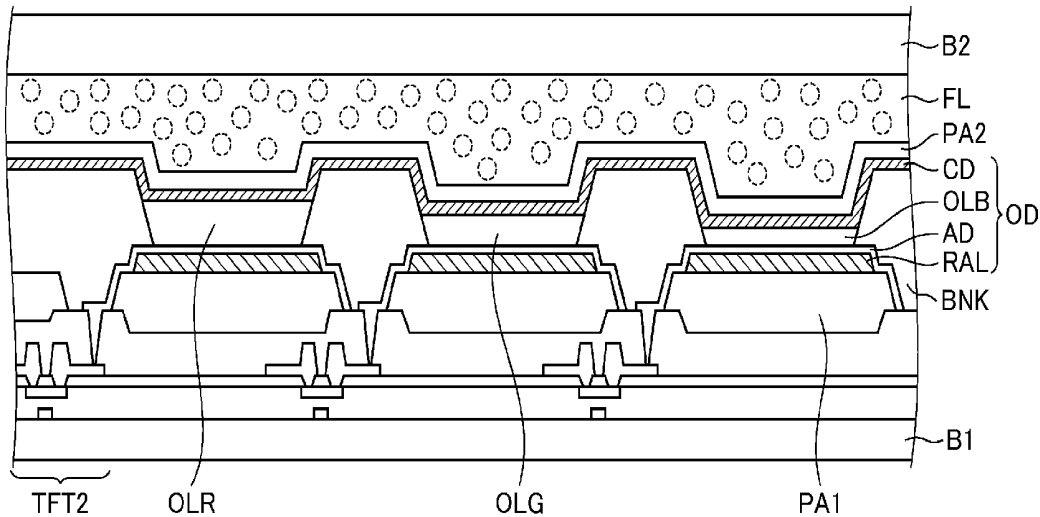

FIG. 1

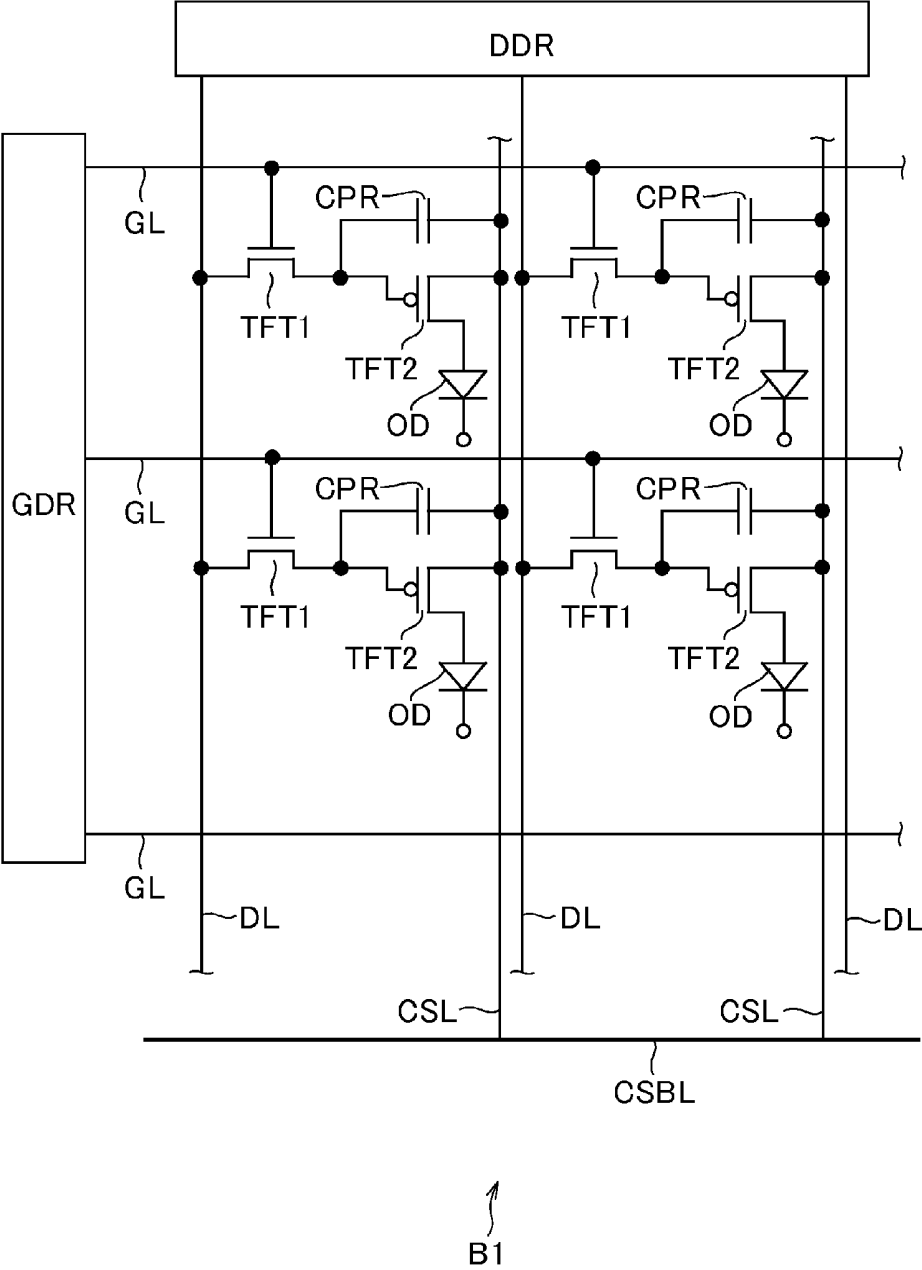
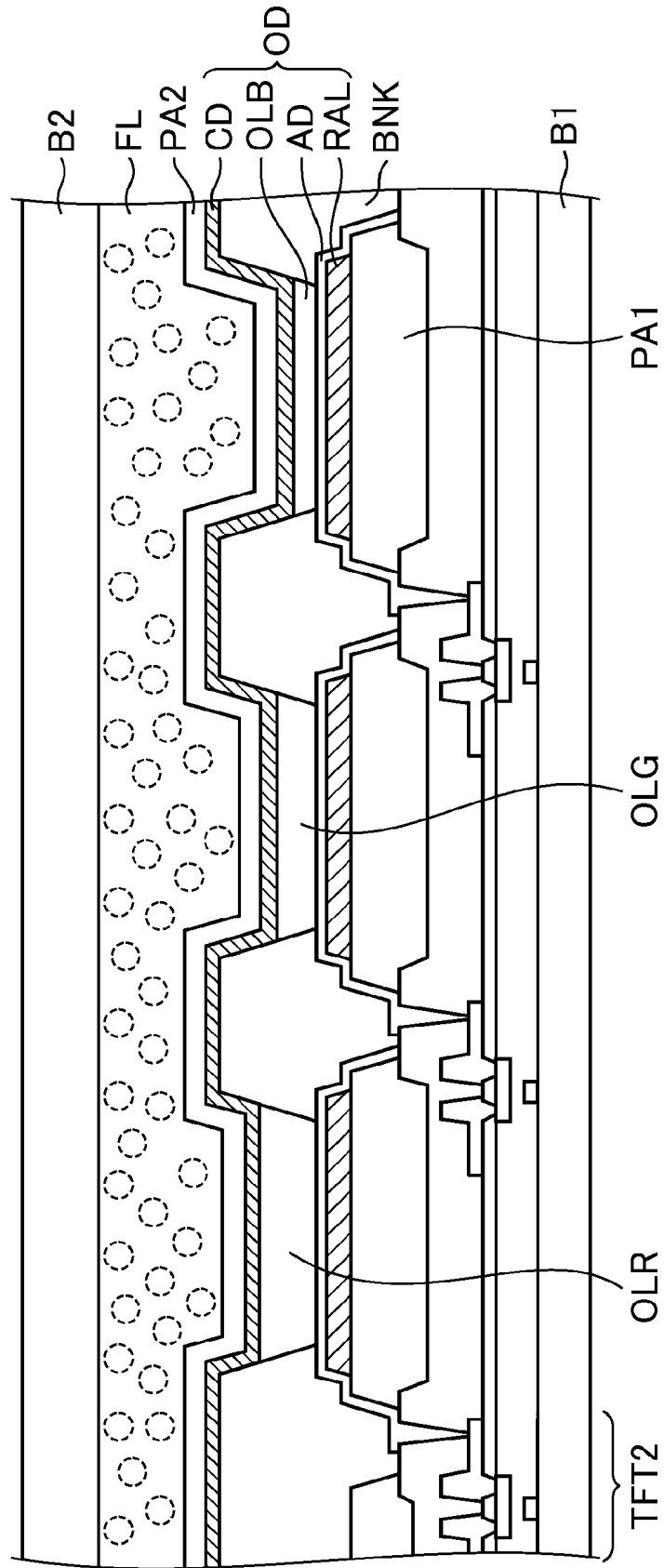



FIG.3



## DISPLAY DEVICE

### CROSS-REFERENCE TO RELATED APPLICATION

**[0001]** This application is a continuation of U.S. patent application Ser. No. 14/146,807, filed on Jan. 3, 2014 which claims the priority from Japanese application JP2013-000247 filed on Jan. 4, 2013, the entire content of which is hereby incorporated by reference into this application.

### BACKGROUND OF THE INVENTION

**[0002]** 1. Field of the Invention

**[0003]** The present invention relates to a light emission display device.

**[0004]** 2. Description of the Related Art

**[0005]** In a top emission type light emission display device, a micro-cavity structure is known which utilizes a light resonance effect between two electrodes constituting a light emission device to enhance the intensity of extracted light.

**[0006]** In the micro-cavity structure, reflection is repeated between a reflection electrode formed under a light-emission layer and a semi-transparent electrode formed on the light-emission layer. The thicknesses of respective layers stacked between the two electrodes are set in such a manner that light emitted by the light-emission layer is enhanced and extracted to a top side.

**[0007]** JP H11-329742 A describes that a light diffusion color filter having a light diffusion property is provided on a light-extraction side of an organic light-emission layer.

### SUMMARY OF THE INVENTION

**[0008]** In the top emission type light emission display device having the micro-cavity structure, high-luminance light can be extracted on the front side. However, the intensity of light may be easily reduced in an oblique direction.

**[0009]** Moreover, in a case of providing the light diffusion color filter, the viewing angle characteristics are improved. However, light is diffused within the color filter and therefore light exiting to the outside can be easily attenuated in the color filter, resulting in reduction in luminance.

**[0010]** In view of the above problems, it is an object of the invention to provide a top emission type light emission display device which can achieve a lower reduction in luminance and can improve the viewing angle characteristics. The above and other objects and novel features of the invention will be made apparent by the description in this specification and the accompanying drawings.

**[0011]** In view of the above problems, a light emission display device according to the invention includes a first substrate, a plurality of light emission devices arranged on the first substrate, a second substrate arranged above the first substrate, a filling layer arranged between the first substrate and the second substrate, and displays an image on the second substrate side. The light emission display device is characterized in that the light emission devices each include a light-emission layer, a reflection electrode formed below the light-emission layer and reflecting light from the light-emission layer upwards, and an upper electrode formed above the light-emission layer and having a light transmission property and reflectivity, a structure for resonating the light emitted by the light-emission layer is formed between the reflection electrode and the upper electrode, and the filling layer includes

fine particles for diffusing the light resonated by the structure and exiting from the upper electrode, added therein.

**[0012]** In an aspect of the light emission display device according to the invention, the light emission display device may be characterized in that the fine particles having diameters from 300 nm to 30 μm are included in the filling layer.

**[0013]** In another aspect of the light emission display device according to the invention, the light emission display device maybe characterized in that the second substrate includes a color filter layer formed to correspond to the plurality of light emission devices, respectively, and a black matrix.

**[0014]** In still another aspect of the light emission display device according to the invention, the light emission device may be characterized in that the light-emission layers of the plurality of light emission devices are formed to be painted in a plurality of colors to emit light of the plurality of colors.

**[0015]** According to the invention, a top emission type light emission display device can be provided, which can achieve a lower reduction in luminance and can improve the viewing angle characteristics.

### BRIEF DESCRIPTION OF THE DRAWINGS

**[0016]** FIG. 1 is an equivalent circuit diagram of a light emission display device according to a first preferred embodiment of the invention.

**[0017]** FIG. 2 is a schematic cross-sectional view of the light emission display device according to the first preferred embodiment.

**[0018]** FIG. 3 is a schematic cross-sectional view of the light emission display device according to a second preferred embodiment of the invention.

### DETAILED DESCRIPTION OF THE INVENTION

**[0019]** Light emission display devices according to respective preferred embodiments of the invention will be described below, referring to the drawings.

#### First Preferred Embodiment

**[0020]** A light emission display device according to the first preferred embodiment is a top emission type light emission display device and is configured to include a first substrate B1 (light emission device substrate) on which light emission devices are formed in a matrix on the pixel-by-pixel basis, a second substrate B2 arranged on a side of the first substrate B1 on which a display region for displaying an image is formed, and a filling layer FL arranged between the first substrate B1 and the second substrate B2.

**[0021]** FIG. 1 is a circuit diagram of an exemplary circuit provided on the first substrate B1 in the above-described light emission display device. On the first substrate B1 in FIG. 1, a number of scanning lines GL extend horizontally in FIG. 1 with a regular interval therebetween, and a number of video signal lines DL extend vertically in FIG. 1 with a regular interval therebetween. The scanning lines GL and the video signal lines DL section respective pixels arranged in a matrix on the first substrate B1. For each pixel, a thin film transistor TFT1 which has an MIS (Metal-Insulator-Semiconductor) structure and is used for switching, a thin film transistor TFT2 used for driving a light-emission device, a storage capacitor CPR, and a light emission device OD are formed. A power supply lines CSL for supplying a power source to the light emission device OD extends vertically in FIG. 1 parallel to

the video signal lines DL. The scanning lines GL and the video signal lines DL are connected to and driven by a scanning line driving circuit GDR and a video line driving circuit DDR, respectively. Each power supply line CSL is connected to a power supply bus line CSBL from which a current is supplied.

**[0022]** In the circuit diagram of FIG. 1, when a row of pixels is selected by application of a gate voltage to a scanning line GL and a video signal is supplied from a video signal line DL, the thin film transistor TFT1 for switching is turned ON and the storage capacity CPR is charged. When the storage capacity CPR is charged, the thin film transistor TFT2 for driving which supplies a current to the light emission device OD is turned on. Thus, the current flows from the power supply line CSL to the light emission device, so that the light emission device emits light.

**[0023]** FIG. 2 is a schematic cross-sectional view of the light emission display device of this preferred embodiment, showing one pixel formed by sub-pixels including an R-pixel, a G-pixel and a B-pixel. As shown in FIG. 2, the thin film transistor TFT2 is formed on the surface of the first substrate B1. The voltage applied to the gate electrode of the thin film transistor TFT2 is controlled by the thin film transistor TFT1 (not shown in FIG. 2) via the storage capacity CPR (not shown in FIG. 2), thereby the current flowing to the lower electrode AD is controlled.

**[0024]** The light emission device OD is arranged on a protection layer PA1 and is formed while being surrounded by a bank layer BNK which sections a pixel region in a grid. This light emission device OD is formed by arranging an organic light-emission layer OEL (organic EL film) between a lower electrode AD and a semi-transparent upper electrode CD provided on the upper side.

**[0025]** Under the lower electrode AD, the reflection electrode RAL is arranged. The upper electrode CD is covered by a protection layer PA2 formed by an SiN film for shielding the light emission device OD from water and an air.

**[0026]** The lower electrode AD in this preferred embodiment is formed of indium tin oxide (ITO) capable of transmitting light. The reflection electrode RAL is formed from metal such as aluminum to have high reflectivity. The upper electrode CD is formed by using an alloy film containing metal such as aluminum or silver in such a thickness that it can transmit light, thereby having a light transmission property and reflectivity. The upper electrode CD serves as a cathode and is formed over an approximately entire surface in a display region which displays a video as an electrode common to the respective pixel regions. The lower electrode AD serves as an anode. The lower electrode AD and the reflection electrode RAL are formed in each pixel region individually. The organic light-emission layer OEL is formed by stacking a hole transportation layer, a light-emission layer, and an electron transportation layer in that order from the bottom. The organic light-emission layer OEL in this preferred embodiment emits white light and is formed to have the same thickness in the R-, G-, and B-pixels, as shown in FIG. 2.

**[0027]** In the light-emission layer in the organic light-emission layer OEL, a hole injected from the lower electrode AD and an electron injected from the upper electrode CD are recombined, thereby light is emitted. Moreover, the light emission display device in this preferred embodiment is a top emission type in which an image is displayed on the side of the first substrate B1 on which the light emission devices OD are formed, and light emitted from the organic light-emission

layer OEL is repeatedly reflected between the reflection electrode RAL and the upper electrode CD and is then extracted from the upper electrode CD which is semi-transparent. In other words, in the light emission display device of this preferred embodiment, a micro-cavity structure is employed in which a light resonance effect is made to occur between the reflection electrode RAL and the upper electrode CD. The thicknesses of the respective layers in the organic light-emission layer OEL are strictly controlled in such a manner that white light extracted in a direction perpendicular to the upper electrode CD is enhanced by interference.

**[0028]** In the light emission display device of this preferred embodiment, fine particles each having diameters from 300 nm to 30  $\mu$ m are mixed in the filling layer FL arranged between the first substrate B1 and the second substrate B2. Due to the fine particles, light exiting from the upper electrode CD perpendicularly is diffused and enters a red color filter layer CFR, a green color filter layer CFG, and a blue color filter CFB which are formed in the second substrate B2. The diameters of the fine particles are desirably measured by dynamic light scattering. In this specification, an average particle diameter means a volume average particle diameter unless specifically stated.

**[0029]** Therefore, in the light emission display device of this preferred embodiment, light extraction efficiency is improved by the micro-cavity structure. Also, emitted light having high directionality in the perpendicular direction is diffused in the filling layer FL and then enters the respective color filter layers, thereby the viewing angle characteristics are improved. In addition, because the light is diffused before entering to the second substrate B2 having the black matrix BM, improvement of the viewing angle characteristics can be achieved with reducing adverse effects on adjacent pixels.

**[0030]** The light emission light-emission layer OEL can be formed by vapor deposition or printing. The filling layer FL is formed by dropping a filling material with light diffusion fine particles mixed therein by means of a dispenser to the inside of a dam member which is formed along an outer periphery of the first substrate B1 to surround a region where the filling layer FL is to be formed. Then, the first substrate B1 is bonded to the second substrate B2 by pressurization or a vacuum process, for example, and thereafter a process such as light curing or heat curing is performed, as necessary. When the second substrate B2 is bonded to the first substrate B1, the second substrate B2 is placed on the first substrate B1 in such a manner that the positions of the color filter layers CFR, CFG, and CFB are aligned with the light emission devices OD, respectively. By mixing the light diffusion fine particles into the filling material to be dropped as the filling layer FL, the light diffusion layer for improving the viewing angle characteristics of the light emission display device having the micro-cavity structure can be formed without largely increasing the manufacturing processes.

**[0031]** For evenly diffusing light in a visible region, the light diffusion fine particles to be mixed into the filling layer FL desirably include fine particles having particle sizes from 300 nm to 700 nm (fine particles having an average particle diameter from 300 nm to 700 nm) corresponding to the wavelength of the light emitted by the light emission device OD. Moreover, as the light diffusion fine particles to be added in the filling layer FL, fine particles having particle sizes from 300 nm to 500 nm (fine particles having an average particle diameter from 300 nm to 500 nm) corresponding a blue component of white light may be contained, so that light

having a wavelength of 400 nm, corresponding to blue light, is more strongly scattered than light having wavelengths of 500 nm and 600 nm, corresponding to green light and red light. Because the wavelength corresponding to blue light is shorter than other wavelengths, control of the film thickness for making the light resonance effect occur tends to be strict. However, by making fine particles having diameters from 300 nm to 500 nm or from 350 nm to 450 nm (fine particles having an average particle diameter from 300 nm to 500 nm or from 350 nm to 450 nm) be contained, for example, blue emitted light can be strongly scattered to compensate the display characteristics of the light emission display device. Also, likelihood of process can be improved.

**[0032]** The light diffusion fine particles may be inorganic material or organic material. When the light diffusion fine particles are mixed in the filling material, dispersant may be added which promotes dispersion of the fine particles. Moreover, the filling layer FL may be formed by resin for sealing each light emission device OD, and may be configured to further contain desiccant for protecting the light emission devices OD from water.

#### Second Preferred Embodiment

**[0033]** Next, a light emission display device according to the second preferred embodiment of the invention is described. The light emission display device of the second preferred embodiment is a top emission type light emission display device as in the first preferred embodiment, but is different from the light emission display device of the first preferred embodiment in that the respective organic EL light-emission layers OEL are formed to be painted in three colors including R, G, and B.

**[0034]** FIG. 3 is a schematic cross-sectional view of the light emission display device of the second preferred embodiment, showing one pixel constituted by sub-pixels including an R-pixel, a G-pixel, and a B-pixel. As shown in FIG. 3, in the light emission display device of the second preferred embodiment, organic EL light-emission layers OLR, OLG and OLB which emit red light, green light, and blue light, respectively, and have different thicknesses from one another are formed, and three kinds of light emission devices OD are formed which respectively emit red light, green light, and blue light. The respective layers forming the light emission light-emission layers OLR, OLG, and OLB have thicknesses each of which is individually determined to enhance emission of red light, green light, and blue light by the resonance effect between the reflection electrode RAL and the upper electrode CD.

**[0035]** In the light emission display device in the second preferred embodiment, a structure for resonating light is employed in each of the light emission light-emission layers OLR, OLG, and OLB. Therefore, light emission efficiency and color purity of each of red light, green light, and blue light can be improved. In addition, the filling layer FL with the fine particles from 300 nm to 30  $\mu$ m (or fine particles having an average particle diameter from 300 nm to 30  $\mu$ m) added therein can diffuse strongly directional emitted light having high luminance in the front direction. Thus, the viewing angle characteristics can be improved.

**[0036]** Moreover, in the light emission display device of the second preferred embodiment, the second substrate B2 is configured to include a linear polarizing plate and a retardation plate to have a function of a circular polarizing plate. Also in the second substrate B2 of the light emission display device

of the first preferred embodiment, for example a linear polarizing plate and a retardation plate may be arranged in the outside of the color filter layers CFR, thereby having a function of a circular polarizing plate.

**[0037]** The light diffusion fine particles mixed in the filling layer FL of the second preferred embodiment desirably include particles having particle sizes from 300 nm to 700 nm (fine particles having an average particle diameter from 300 nm to 700 nm) as in the first preferred embodiment. Moreover, by making the filling layer FL contain fine particles having particle sizes from 300 nm to 500 nm (or from 350 nm to 450 nm) corresponding to the blue light emission device ODB, the display characteristics of the light emission display device can be compensated and the likelihood of the process can be also improved. Moreover, the light diffusion fine particles to be mixed into the filling layer FL desirably include fine particles having an average particle diameter from 300 nm to 500 nm (or from 350 nm to 450 nm). Furthermore, for example, the light diffusion fine particles may be added in the filling layer FL so that one of blue emitted light, green emitted light, and red emitted light is more strongly scattered than others and the area of the light emission light-emission layer corresponding to that one emitted light may be formed to be smaller than the areas of the light emission light-emission layers corresponding to other emitted light.

**[0038]** In the above-described preferred embodiments, light of three colors including red, green, and blue is extracted from the second substrate B2 side. Alternatively, the second substrate B2 of the first preferred embodiment may include a white color filter to form an image with four colors including red, green, blue, and white, or in the second preferred embodiment a light emission layer for emitting white light may be formed by being painted in white separately. Moreover, even in the light emission display device in which the light emission light-emission layers are painted in different colors as in the second preferred embodiment, color filters or a black matrix may be formed in the second substrate B2. Furthermore, the light emission display devices of the respective preferred embodiments have a circuit structure shown in FIG. 1, but may have a different circuit structure from FIG. 1.

**[0039]** The invention is not limited to the above-described preferred embodiments, but can be modified in various ways. For example, the structure described in each preferred embodiment can be replaced with substantially the same structure, the structure providing the same operation and effects, or the structure which can achieve the same object.

**[0040]** While there have been described what are at present considered to be certain embodiments of the invention, it will be understood that various modifications may be made thereto, and it is intended that the appended claims cover all such modifications as fall within the true spirit and scope of the invention.

What is claimed is:

1. A display device comprising:

- a first substrate;
  - a plurality of light-emission devices above the first substrate; and
  - a filling layer covering the plurality of light-emission devices,
- wherein each of the plurality of light-emission devices includes:
- a light-emission layer;
  - a reflection electrode below the light-emission layer to reflect light from the light-emission layer;

- a bank configured to cover an edge of the reflection electrode; and
- an upper electrode above the light-emission layer and having a light transmission property and reflectivity, the filling layer includes fine particles dispersed therein configured to uniformly diffuse the light in a visible wavelength region exiting from the upper electrode, the filling layer spreads both above the light-emission layer and above the bank continuously, and the fine particles are dispersed in the filling layer both above the light-emission layer and above the bank.
2. The display device according to claim 1, further comprising a protection layer covering the plurality of light-emission devices.
3. The display device according to claim 2, wherein the protection layer is between the upper electrode and the filling layer, and the upper electrode and the filling layer are spaced at an interval which is smaller than the thickness of the filling layer.
4. The display device according to claim 2, further comprising a second substrate above the protection layer.
5. The display device according to claim 1, wherein the light-emission layer is between the reflection electrode and the upper electrode, a first space between the reflection electrode and the upper electrode at one of the plurality of light-emission devices is different from a second space between the reflection electrode and the upper electrode at another of the plurality of light-emission devices.

\* \* \* \* \*

专利名称(译)	显示设备		
公开(公告)号	<a href="#">US20160133877A1</a>	公开(公告)日	2016-05-12
申请号	US15/001554	申请日	2016-01-20
[标]申请(专利权)人(译)	株式会社日本显示器		
申请(专利权)人(译)	日本展示INC.		
当前申请(专利权)人(译)	日本展示INC.		
[标]发明人	MATSUMOTO YUKO SATO TOSHIHIRO OOKA HIROSHI		
发明人	MATSUMOTO, YUKO SATO, TOSHIHIRO OOKA, HIROSHI		
IPC分类号	H01L51/52 H01L27/32		
CPC分类号	H01L51/5268 H01L27/3246 H01L51/5253 H01L2251/558 H01L51/524 H01L51/5203 H01L51/5271 H01L27/322 H01L27/3244 H01L51/5246 H01L51/5265 H01L51/5284 H01L2251/5315		
优先权	2013000247 2013-01-04 JP		
外部链接	<a href="#">Espacenet</a> <a href="#">USPTO</a>		

摘要(译)

一种有机EL显示装置，包括：第一基板；多个有机EL器件，设置在第一基板上；第二基板，设置在第一基板上；填充层，设置在第一基板和第二基板之间，并显示图像第二基板侧。有机EL显示装置的特征在于：有机EL器件各自具有发光层，形成在发光层下方并将来自发光层的光向上反射的反射电极，以及形成在发光层上方的上电极。发光层，具有透光性和反射性；在反射电极和上电极之间形成用于使由发光层发射的光谐振的结构；填充层包括用于扩散从加入其中的上电极射出的光的微粒。

